

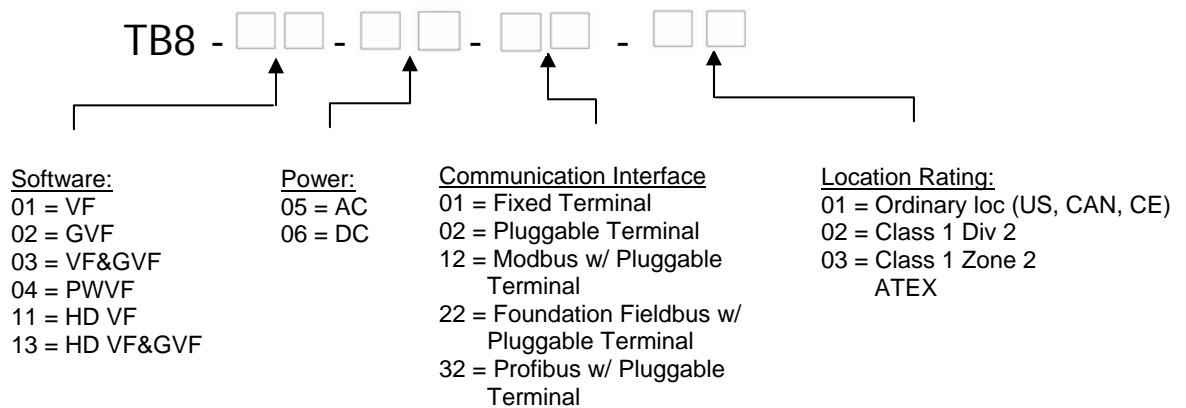

## SONARtrac® Process Monitoring System – Transmitter Assembly

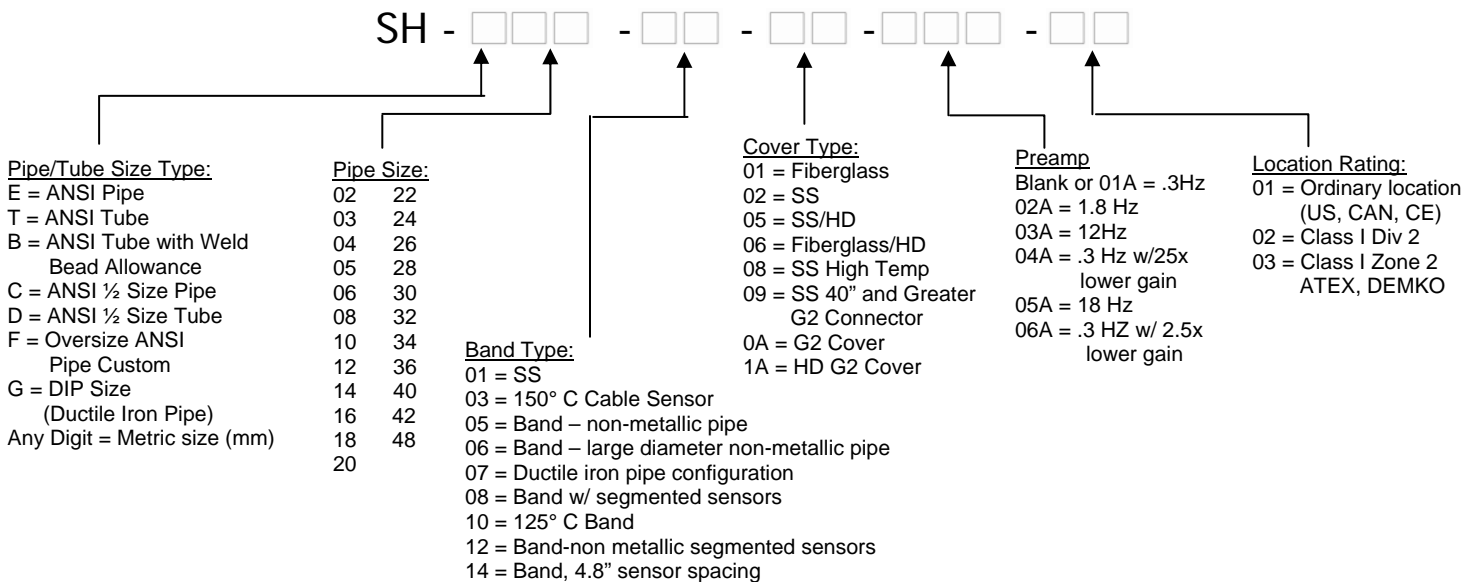

## SONARtrac® Process Monitoring System – Sensor Head Assembly



**SONARtrac<sup>®</sup> Sensor Head Cable**

CA -  -

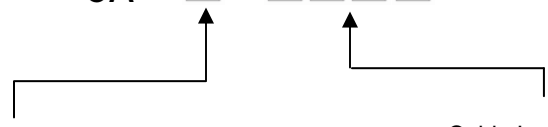

<u>Cable Type:</u>	<u>Cable Length (feet):</u>	
1 = Standard (-20°C to 105°C)	0005	0200
3 = Interlock Armored Low Temperature (CSA) (-40°C to 105°C; 75°C in wet locations)	0010	0225
5 = G2 Standard (-20°C to 105°C)	0025	0250
6 = G2 Interlocked Armor Low Temperature (CSA) (-40°C to 105°C; 75°C in wet locations)	0050	0275
7 = Interlocked Armor Low Temperature (UL) (-40°C to 105°C; 75°C in wet locations)	0075	0300
8 = G2 Interlocked Armor Low Temperature (UL) (-40°C to 105°C; 75°C in wet locations)	0100	0350
9 = G2 Standard, Zone 2 (-20°C to 105°C)	0125	0375
10=G2 Standard, Pinned Connector	0150	0400*
11=G2 Interlock Armored Low Temperature (CSA), Pinned Connector (-40°C to 105°C; 75°C in wet locations)		CA-14 Cable Only
12= G2 Interlock Armored Low Temperature (UL), Pinned Connector (-40°C to 105°C; 75°C in wet locations)		
13=G2 Standard, Zone 2, Pinned Connector (-20°C to 105°C)		
14=G2 Interlock Armored Low Temp, Pinned Conn (-40°C), Extended Length (400 ft), General Purpose Location Only*		
17=G2 ATEX Braided Armor, -40°C to 90°C.		