	<b>SONARtrac™ Technical Note</b>	
	<b>TN0002</b>	
	<b>Subject: Non-HD / Non-Segmented Product Sensor Band Installation Overview</b>	
		Date: 20Ago07
		Revision   02
		Page 1 of 5

**Question:**

Please provide an overview of how to install a sensor band.

**Answer: Non-HD / Non-Segmented Product Sensor Band Installation Overview**

Position the SONARtrac sensor band assembly on the pipe with the polyimide film (amber colored) against the pipe surface. If possible, orient the flow direction arrow on the sensor assembly with the direction of flow within the pipe. Note: If this is not possible due to installation constraints, e.g. access to sensor fasteners, install opposite to flow direction. The transmitter must be re-configured for “reverse flow” during its set up as detailed in the Transmitter Startup & Operation Section of the manual.

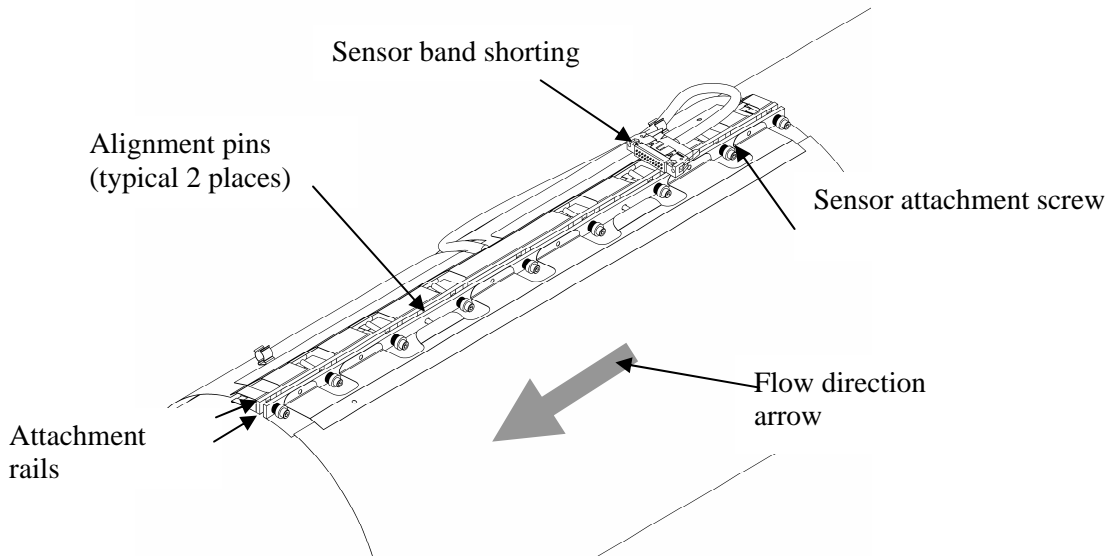



Figure 1 Sensor Band Screw and Alignment Pins

Wrap the sensor band around the pipe and slide the alignment pins on the attachment rail through their mating holes on the opposite attachment rail. If the process pipe has a welded seam, align the gap between the sensor attachment rails along the pipe weld seam. Final positioning can be made after the sensor screws have been started. **Note:** When installing the sensor band keep in mind the requirement for transmitter connector socket assembly orientation as described in Section 5.7. If necessary, due to cover installation constraints, wrap the sensor band over the weld seam.

Carefully start threading the screws into their screw holes (avoid cross threading) by using the hex driver until each screw is engaged about 2 turns. Once all screws are engaged make final positioning of the sensor assembly with respect to pipe weld seam or desired

CiDRA Corporate Services	50 Barnes Park North	Wallingford, CT 06492
Tel. 203-265-0035	Fax. 203-294-4211	www.cidra.com

	<b>SONARtrac™ Technical Note</b>	
	<b>TN0002</b>	
	<b>Subject: Non-HD / Non-Segmented Product Sensor Band Installation Overview</b>	
		Date: 20Ago07
		Revision 02
		Page 2 of 5

orientation on the pipe. The following table provides guidance for selecting the proper hex tool and spacer gauge.

Sensor Band P/N	Spacer Gauge P/N	Socket Head Screw Hex Size (inch)	Band Attachment Rail Size (Ref)
20380- ALL SIZES	20143-01	7/64	1/8 x 3/8
20409- ALL SIZES	20143-02	7/64	1/8 x 3/8
20686- ALL SIZES	20143-04	5/32	1/4 x 1/2

Table 1 Gauge Block and Screw Size

Start with the center most screw and tighten screws, alternating from side to side, 3 - 4 turns at a time. Refer to Figure 2 for the screw tightening sequence. **Note:** Repeat the tightening sequence only until the Belleville disc springs on the screws begin to compress. The sensor screw stack up assembly is illustrated in Figure 3.

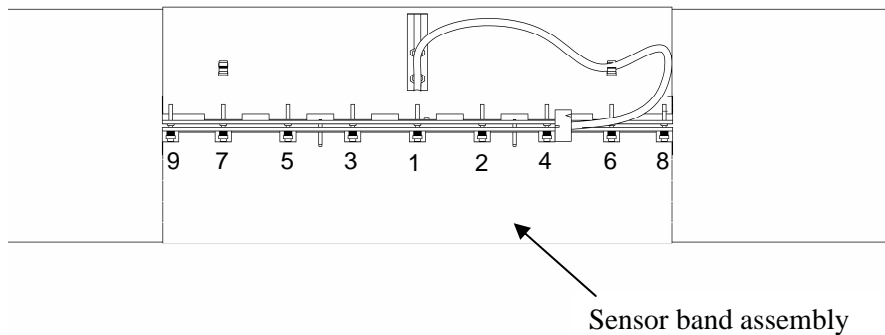

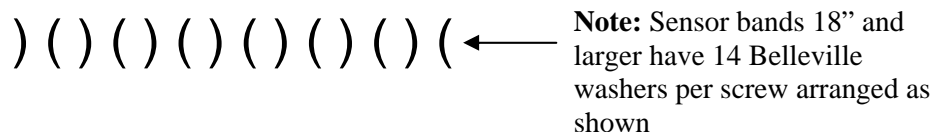
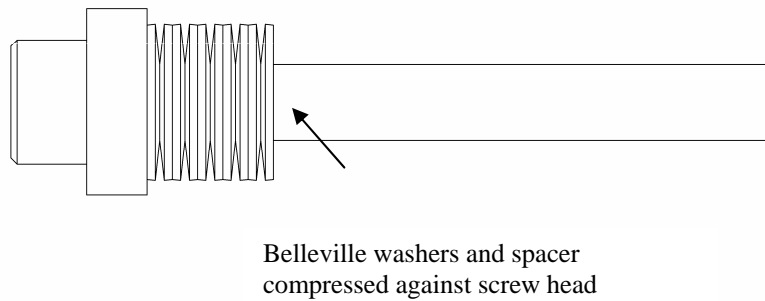
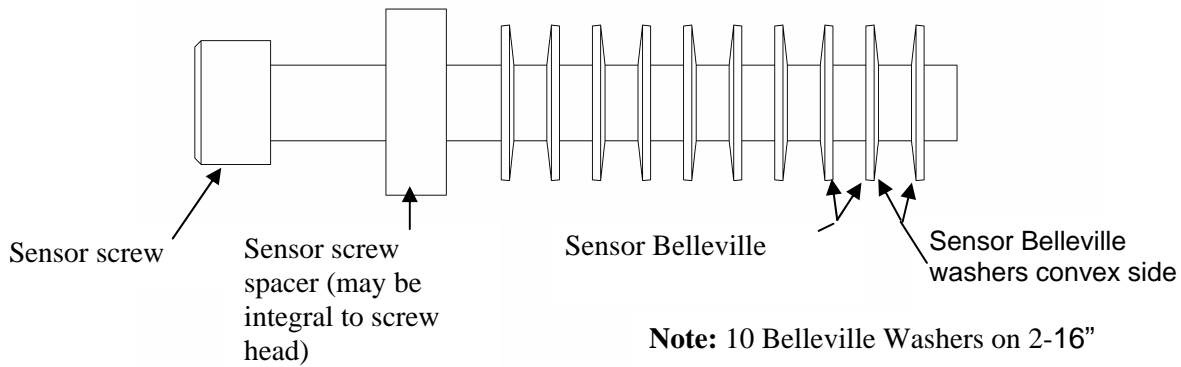

Figure 2 Sensor Band Screw Tightening Sequence

CiDRA Corporate Services	50 Barnes Park North	Wallingford, CT 06492
Tel. 203-265-0035	Fax. 203-294-4211	www.cidra.com

	<b>SONARtrac™ Technical Note</b>	
	<b>TN0002</b>	
	<b>Subject: Non-HD / Non-Segmented Product Sensor Band Installation Overview</b>	
	Date: 20Ago07	
	Revision	02
	Page 3 of 5	



*Figure 3      Sensor Band Screw Assembly*

Further tightening of the sensor band screws is made while using the sensor band spacer tool (shown below) furnished with the sensor band. The spacer tool is used to set the compression on the Belleville washers referred to above. Refer to Table 3 for the appropriate spacer tool based on sensor band part number.



*Figure 4      Sensor Band Spacer Tool*

CiDRA Corporate Services	50 Barnes Park North	Wallingford, CT 06492
Tel. 203-265-0035	Fax. 203-294-4211	www.cidra.com

	<b>SONARtrac™ Technical Note</b>	
	<b>TN0002</b>	
	<b>Subject: Non-HD / Non-Segmented Product Sensor Band Installation Overview</b>	
		Date: 20Ago07
		Revision 02
		Page 4 of 5

Using the sensor band screw tightening sequence shown in Figure 2, insert the sensor screw spacer tool over the Belleville washers on the middle sensor screw assembly and tighten it such that it is snug but the spacer tool can still be removed. The following figure illustrates use of the sensor band screw spacer tool.

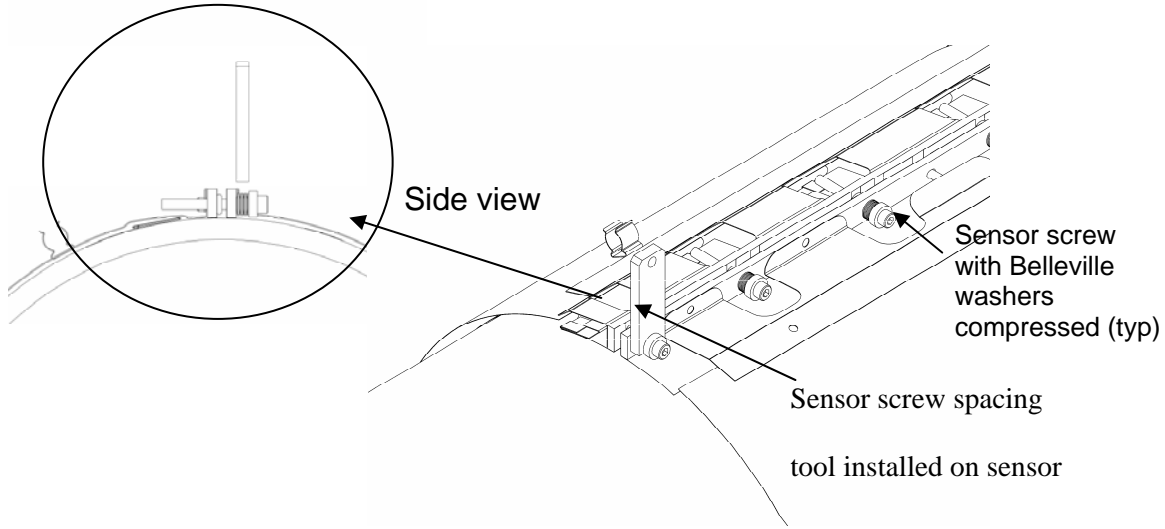



Figure 5 Sensor Band Spacing Tool Installed on Sensor Screw

**Note:** Ensure the spacer tool is perpendicular to the attachment rail to ensure proper tightness. Remove the tool, move to the next sensor screw, and repeat the tightening on each of the sensor screws.

Please contact CiDRA Technical Support if there are any questions.

CiDRA Corporate Services	50 Barnes Park North	Wallingford, CT 06492
Tel. 203-265-0035	Fax. 203-294-4211	www.cidra.com

	<b>SONARtrac™ Technical Note</b>	
	<b>TN0002</b>	
	<b>Subject:</b> Non-HD / Non-Segmented Product Sensor Band Installation Overview	
	Date: 20Ago07	
	Revision	02
	Page 5 of 5	

### Revision History

Rev	Date	Changed By	Approved By	Change Description
01	8/22/07	B. Markoja	M. Sapack	Initial Release
02	7/29/08	V. Rojas-Haines	V. Rojas-Haines	Update figures and name

CiDRA Corporate Services	50 Barnes Park North	Wallingford, CT 06492
Tel. 203-265-0035	Fax. 203-294-4211	www.cidra.com