

CiDRA[®]	SONARtrac[®] Technical Note	
	TN0012	
	Subject: SONARtrac VF-100 System Single Line Electrical Diagram	
	Date: 30Jul08	
	Revision	02
	Page 1 of 2	

Question:

Please provide a single line electrical drawing of the SONARtrac system.

Answer:

Please refer to the following:

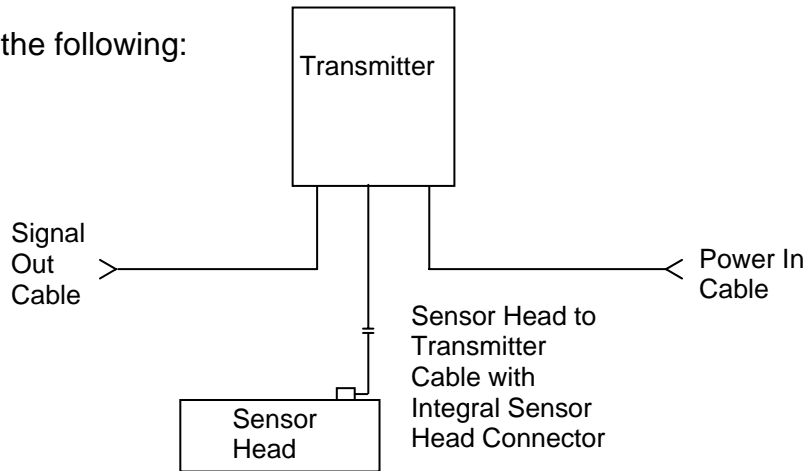

Cable Designation	Cable Description	Comments
Power In	AWG 24 minimum to AWG 12 maximum (0.511 mm to 2.05 mm) with ground	User supplied
Sensor Head to transmitter with Integral Sensor Head Connector	12 twisted pairs of 20 AWG conductors with an overall cable shield encased in a PVC jacket. The standard cable has an operating range of -4 °F to 221 °F (-20 °C to 105 °C). The cable is UL Listed (UL Standard 13, Type PLTC) and CSA Certified (CSA C22.2 No. 214, PCC FT4). The outer diameter of the cable is 0.61 inch (15.5 mm) nominal. Optional flexible conduit available	Factory installed NEMA 4X connector for attachment to sensor head. Cable length cut to order at installation. Class I Div 2 rated system maximum cable length is 300 feet (91.4 meter). ATEX Zone 2 rated system maximum cable length is 375 feet (114 meter).
Signal Out	AWG 22 to AWG 16 (0.645 mm to 1.29 mm) with shield	User supplied

Please contact CiDRA Customer Support for additional information.

CiDRA Corporate Services	50 Barnes Park North	Wallingford, CT 06492
Tel. 203-265-0035	Fax. 203-294-4211	www.cidra.com



SONARtrac[®] Technical Note

TN0012

**Subject: SONARtrac VF-100 System
Single Line Electrical Diagram**

Date: 30Jul08

Revision 02

Page 2 of 2

Revision History

Rev	Date	Changed By	Approved By	Change Description
01	12Mar08	Markoja	Markoja	Initial Release
02	30Jul08	B. Markoja	B. Markoja	Revision #2